

EB35EDE-IX

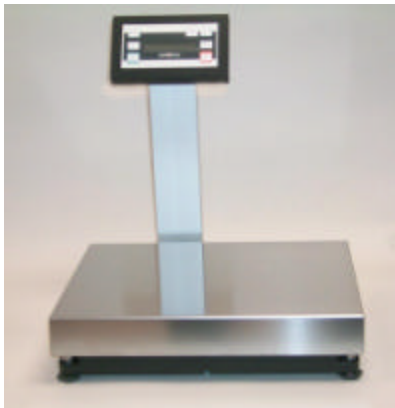

SPECIFICATIONS:

| | | | |
|-------------------|-----------------------------|----------------------|-----------------------|
| Weighing Capacity | 35 kg or 77 lb. | Platform Size (WxD) | 15.7" x 11.8" |
| Readability | 1.0 g or 0.002 lb. | Dimensions (WxHxD) | 15.7" x 11.8" x 3.6" |
| Linearity | $\leq \pm 1.0g$ or 0.002lb. | Display Dim. (WxHxD) | 6.9" x 4.1" x 0.5" |
| Reproducibility | $\leq \pm 2.0g$ or 0.005lb. | Net Weight | 8 kg or 17 lb. |
| Response Time | < 0.5 seconds | Type of Display | Backlit LCD |
| Operating Temp. | -10 to +40°C(+14 to 104°F) | Overload Capacity | 70 kg or 154 lb |
| Protection Rating | IP54 (platform only) | Polyrange Setting | 17.5/35 kg x 0.5/1.0g |

FEATURES:

Intrinsically Safe Construction

The EB-IX scales can be used in hazardous environments Factory Mutual approved for Class 1, Division 1, Groups A, B, C, D.

Multiple Built-in Application Programs

EB-IX series scales come standard with application programs including: counting, toggling between units, % weighing, net total formulation, 2nd Tare Memory, totalizing, toggling between gross and net, calculation by a factor and averaging (animal weighing).

User Friendly Menu Setting and Operation

Function key labels guide the user through the menu and applications. The keyboard has large clearly marked keys that give you instant tactile feedback. The backlit display offers optimal reading even under poor lighting conditions.

IP54 Protection Rating on Platform

The IP54 protection rating let the scales withstand dust and moisture and protects against accidental spills and ingress of dust particles making them suitable for use in the industrial environment.

Safe or Hazardous Area Power Supplies

The EB-IX scales must be ordered with a safe or hazardous power supply. The safe area supply (no.609308-61) has 60' of cable and is easily installed

outside the hazardous area. The hazardous area power supply (no. YPS03-XKR) is approved for use within the hazardous area and must be installed by a licensed electrician.

RS232 Output

Data is capable of being output via an optional Zener barrier (no. YDI02-Z) to be located in the Safe Area. A printer or computer can be run directly from the Zener barrier in the Safe Area.

Mechanically Stable Construction

The EB-IX series are protected against both side impact and overload of up to 2x the capacity of the scale. The scales absorb impact and reliably dissipate the overload forces. The weighing platforms are constructed of high grade stainless steel.

Increased Resolution

A setting can be stored via the menu to increase the resolution into a polyrange readability for the first half of the capacity to twice the initial resolution.

Speed Up Technology

The stabilization time of the EB-IX scales are unequalled with a readout within 0.5 seconds depending on environmental condition. This will allow a faster work pace which in turn increases efficiency and in the long run saves costs.

Sartorius Corporation
131 Heartland Boulevard
Edgewood New York 11717
Toll Free: (800) 635-2906
☎ (631) 254-4249
Fax (631) 254-4261

| | |
|--|----------|
| Sartorius Fax on Demand: (800) 551-3774 | |
| This Document Number: | 20122 |
| Related Documents | # |
| Industrial Catalog | 2000 |
| | |
| | |

EB35EDE-IX

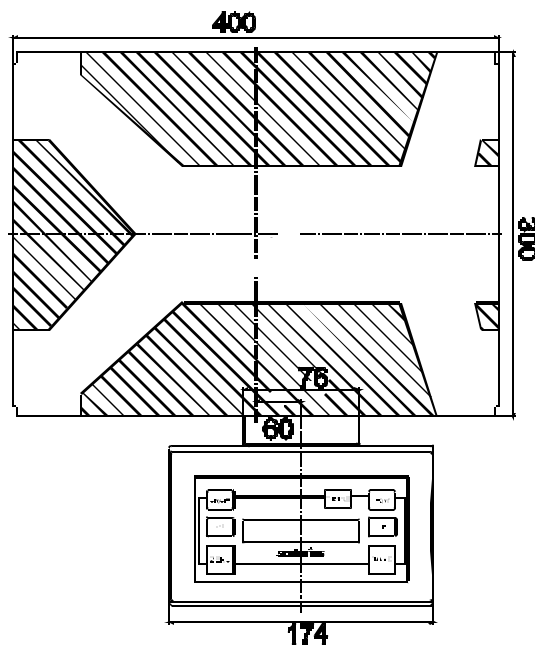
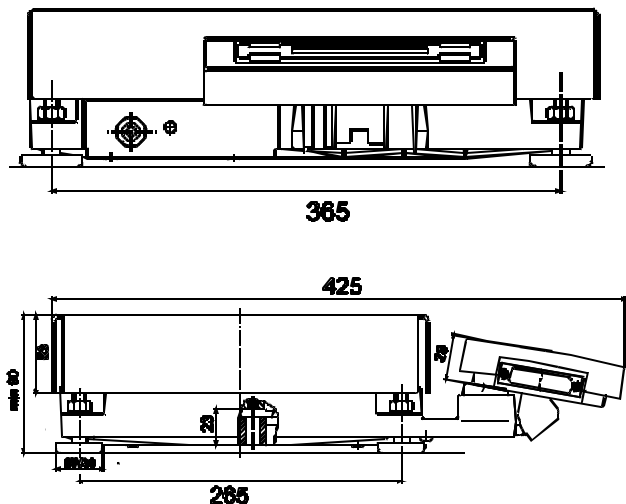

DISPLAY

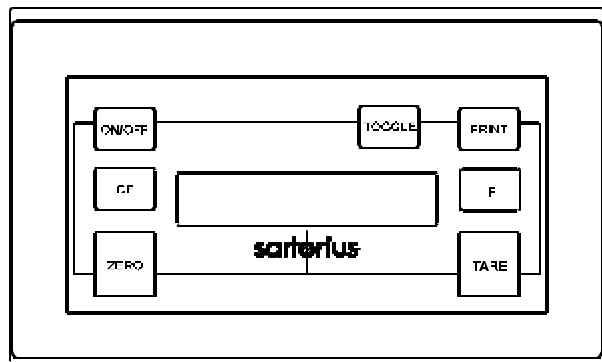

The EB...EDE-X scales come standard with a post mount. The post is 19.7" high (500 mm).

All dimensions are in mm. For inches, divide by 25.4.

Sartorius Corporation
 131 Heartland Boulevard
 Edgewood New York 11717
 Toll Free: (800) 635-2906
 ☎ (631) 254-4249
 Fax (631) 254-4261

| | |
|--|----------|
| Sartorius Fax on Demand: (800) 551-3774 | |
| This Document Number: | 20122 |
| Related Documents | # |
| Industrial Catalog | 2000 |
| | |
| | |